



WOODENDOT

MAIN COLLECTION

LIVE DESIGN

INDEX

ABOUT	4
DESIGN	5
WOOD	6
MADE	7
FOOTPRINT	8

COLLECTIONS 9 - 52

KA LAMP		BATEA		PELICAN	37
S	11	S	24	KESITO	41
M	15	M	28	ETNA	45
XL	19	L	32	ETNA MINI	49

TECHNICAL SPECIFICATIONS 53

CREDITS 65

ABOUT



WOODENDOT was born of the smell of wood from, the passion for design and a number of circumstances and experiences lived by Daniel and María that inspired them around 2013 to set up the firm.

At WOODENDOT we create furniture, accessories and lighting products using wood as the main material; a material that brings our dreams to life. We design products that live in harmony with people, the pivot of our existence.

We combine the know-how of master wood craftsmen with the most innovative proposals from designers. The result is a product with its own identity, the warmth of wood; a product that can respond to new needs while looking to the future thanks to its timeless nature.

Everything we do at WOODENDOT seeks to always look after what we love, nature!

WOODENDOT nace del olor a madera, de la pasión por el diseño y de una serie de circunstancias y experiencias vividas por Daniel y María que les impulsaron allá por el 2013 a fundar la firma.

En WOODENDOT creamos productos de mobiliario, accesorios e iluminación con la madera como material principal, un material que da vida a nuestros diseños. Diseñamos productos por y para que convivan con las personas, nuestra razón de ser.

Fusionamos el saber hacer de maestros artesanos de la madera con las propuestas más innovadoras de diseñadores. El resultado son productos con identidad propia, con la calidez que le aporta la madera, capacitados para dar respuesta a las nuevas necesidades y para mirar al futuro gracias a su carácter atemporal.

Todo lo que hacemos en WOODENDOT trata de cuidar siempre aquello que amamos, la naturaleza!

DESIGN

LIVE DESING! This is our mantra, a mantra that connects all our values:

Live desing!, because our products are designed to live in harmony with people, creating natural, warm, distinctive, timeless spaces.

Live desing!, because we believe in "fewer, but better", fewer products but with more emotional value, easier to use with several functionalities, long-lasting, and transcending mere trends.

Live desing!, because good design and quality go hand in hand. We carefully select all the materials with which our master craftsmen create each of our products.

Live design!, because we create products with personality, friendly, harmoniously balanced and elegant, but always expressive and functional.

Live design! because our products are functional and versatile, adapting to the changing needs of people and contributing to creating environments that share our lives.

Live desing!, because our creativity always seeks innovation at all levels: people, environment, concept, product, processes, collaborations and so on.

Live desing!, because our products are timeless, with identity, that can be integrated into any environment, evolving and accompanying us all our lives.

Live desing!, because nature is living and it provides us with our most prized asset - wood. Looking after it is our commitment and our obligation.

LIVE DESING! Este es nuestro mantra, un mantra que conecta todos nuestros valores:

Live desing!, porque nuestros productos están diseñados para convivir con las personas, creando espacios vivos, cálidos, singulares y perdurables en el tiempo.

Live design!, porque creemos en "menos, pero mejor"; menos productos pero con más valor emocional, más sencillos de usar, con varias funcionalidades, duraderos y ajenos a modas.

Live design!, porque el buen diseño y la calidad van de la mano. Seleccionamos cuidadosamente todos los materiales con los que nuestros maestros artesanos elaboran cada uno de nuestros productos.

Live design!, porque creamos productos con personalidad, amables, equilibrados y elegantes, pero siempre expresivos y funcionales.

Live design!, porque nuestros productos son funcionales y versátiles, adaptándose a las necesidades cambiantes de las personas y contribuyendo a crear entornos vivos.

Live design!, porque nuestra creatividad está permanentemente buscando la innovación a todos los niveles: personas, medio ambiente, concepto, producto, procesos, colaboraciones...

Live design!, porque nuestros productos son atemporales, con identidad, capacitados para integrarse en cualquier ambiente, evolucionando y acompañándonos a lo largo de nuestras vidas.

Live design!, porque la naturaleza está viva y nos proporciona nuestro bien máspreciado, la madera. Cuidar de ella es nuestro compromiso y nuestra obligación.

WOOD

UNIQUE PIECES

We will never find two identical trees in a forest, their rings grow at different rhythms and their colours have an infinite number of subtle differences. Trees are the essence of our products, making each one unique.

SENSATIONS

Smell, touch, see, feel... Wood awakens our senses, enabling us to enjoy a wealth of pleasurable sensations; sensations that take us to a natural, warm, cosy world.

WE LOVE NATURE

When we select wood for our products, as well as quality we also take into account local sourcing and its sustainable origin because this means minimum transportation and the assurance that in the process of its extraction the environment is respected, thereby guaranteeing the future of the forest.

SURFACE TREATMENTS

Wood is a living material therefore it changes over time; with the application of surface treatment we protect the wood, we enhance the intrinsic beauty of the material and prolong its life.

PIEZAS ÚNICAS

En un bosque nunca encontraremos dos árboles iguales, sus anillos se mueven a ritmos distintos y sus aromas y colores tienen infinidad de matices. Los árboles son la esencia de nuestros productos, haciendo único a cada uno de ellos.

SENSACIONES

Oler, tocar, ver, sentir... la madera despierta nuestros sentidos y nos permite disfrutar de un inmenso abanico de sensaciones placenteras, sensaciones que nos trasladan a un mundo natural, cálido y acogedor.

AMAMOS LA NATURALEZA

Cuando seleccionamos madera para nuestros productos, además de calidad, también tenemos en cuenta que su procedencia sea cercana y su origen sostenible, ya que supone un mínimo transporte y la certificación de que en su proceso de extracción se ha respetado el medio ambiente, garantizando así el futuro de los bosques.

TRATAMIENTOS SUPERFICIALES

La madera es un material vivo y, por lo tanto, va cambiando con el paso del tiempo. Con la aplicación de tratamientos superficiales protegemos la madera, realzamos la belleza intrínseca del material y prolongamos su vida.



MADE



CREATIVE COMBINATION: DESIGN, CRAFTSMANSHIP AND TECHNOLOGY

Our products are the result of combining design, craftsmanship and technology. An enriching combination that draws from the very best of creativity, skill and technological advances to generate unique products with strong emotional value.

LOCAL: ÍSCAR

"VILLAGE OF WOOD AND TRADITION"

All our products are made in Íscar (Spain), a village located in the very heart of "Tierra de Pinares" ("Land of Pines"), known for the traditional dedication of its inhabitants to the craft of woodwork.

Íscar is a village that looks to the future without forgetting its past, with firmly rooted, age old customs, a privileged place in which to create our products with a guarantee of the highest quality.

Most of our raw material comes from local suppliers, we support local development and traditional crafts.



FUSIÓN CREATIVA: DISEÑO, ARTESANÍA Y TECNOLOGÍA

Nuestros productos son el resultado de fusionar diseño, artesanía y tecnología. Una fusión enriquecedora que se alimenta de lo mejor de cada uno de estos actores: la creatividad, el buen hacer y de los avances tecnológicos, para generar productos únicos con un alto valor emocional.

LOCAL: ÍSCAR

"VILLA DE MADERA Y SOLERA"

Todos nuestros productos se realizan en Íscar (España), localidad situada en pleno corazón de "Tierra de la Pinares", que cuenta con la tradicional dedicación de sus habitantes en el trabajo artesano de la madera.

Íscar es una localidad que mira al futuro sin olvidar su pasado, de tradicionales y arraigadas costumbres, un lugar privilegiado en el que elaborar nuestros productos y una garantía de máxima calidad.

La mayoría de nuestra materia prima proviene de proveedores locales, apoyamos el desarrollo local y los oficios tradicionales.

FOOTPRINT

Our commitment and our obligation is to look after what we love. This is why day by day we make every endeavour to improve our environmental policy.

REDUCE

We design our products while maximising efficiency and generating minimal waste. Our products are shipped disassembled, thereby allowing smaller packaging while saving energy and volume in transport and the packaging material itself.

LEGACY

We aim to create unique, timeless products that can be handed down from parent to child, thereby increasing their emotional value. We create products with personality that transcend mere trends using top quality materials.

ACTIVISM

We believe that little gestures help to change the world and this is why at Woodendot we make every endeavour to take part in, promote and defend initiatives that improve the environment.

LIFE CYCLE

During the design process, we try to minimize the environmental impact at each stage of the life cycle, from obtaining raw materials to the recycling of each piece.

Our objective is to evaluate and make improvements on an ongoing basis in order to reduce the environmental impact of our products and all our day-to-day activities with initiatives as simple as making the maximum use of natural light to obtaining 100% recyclable packaging.

Cuidar de aquello que amamos es nuestro compromiso y nuestra obligación, y por ello tratamos de mejorar día a día nuestra política medio ambiental.

REDUCIR

Diseñamos productos maximizando la eficiencia y generando los mínimos residuos. Nuestros productos se envían desmontados, permitiendo un packaging reducido, que ahorra energía y volumen en el transporte y en el propio material de embalaje.

HERENCIA

Nuestra intención es crear productos atemporales, únicos, que puedan heredarse de padres a hijos aumentando así su valor emocional. Elaboramos productos con personalidad, al margen de modas y con materiales de primera calidad.

ACTIVISMO

Creemos que los pequeños gestos ayudan a cambiar el mundo. Por ello, en Woodendot tratamos de participar, promover y defender iniciativas que mejoren el medio ambiente.

CICLO DE VIDA

Durante el proceso de diseño, tratamos de minimizar el impacto ambiental en las diferentes etapas del ciclo de vida, desde la obtención de la materia prima hasta el reciclado de cada pieza.

Nuestro objetivo es evaluar y realizar permanentemente mejoras que ayuden a reducir el impacto medio ambiental de nuestros productos y de todas nuestras actividades diarias. Con iniciativas tan simples que incluyen desde el aprovechamiento de la luz natural hasta conseguir un packaging 100% reciclable.

COLLECTIONS

.

COLLECTION

KA LAMP



COLLECTION

KA LAMP S



Ka S is a table lamp which radiates ambient light. It distinguishes itself by its simple and elegant lines, and enhances the curve in its beech wood base, which is ideal to leave small objects in. From its base, a leaning pole arises, incorporating a natural leather detail. The metal lampshade filters the light through a natural cotton diffuser. Available in black and white finish.

Ka S es una lámpara de mesa, que emite luz ambiental. Se caracteriza por sus líneas sencillas y elegantes y destaca la concavidad de su base de madera de haya, ideal para depositar pequeños objetos. De la base nace un mástil inclinado que incorpora un detalle de piel natural. La tulipa de metal tamiza la luz mediante un difusor natural de algodón. Disponible en acabado blanco y negro.



LIVE DESIGN

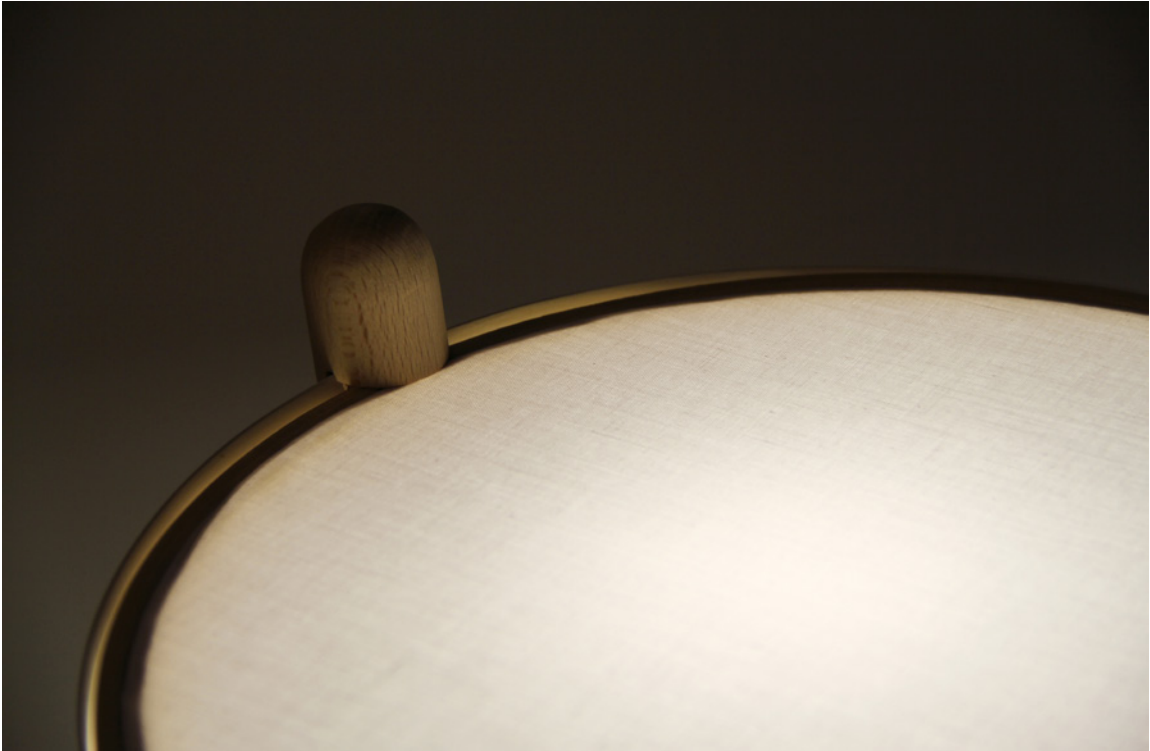



LIVE DESIGN

COLLECTION

KA LAMP M

Ka M is a standard lamp, which radiates direct light. Its simple and elegant lines are drawn from a stylish structure of beech wood slats, a tripod shape and joined together by a leather thread. At the top of the pole is a small metal lampshade which radiates a light that is ideal for reading.

Ka M is available in two versions:

Essential and Functional.

Essential has a minimal character and Functional has a more practical and unique character, as it includes a natural leather tray and a splash of colour in its legs. Both variations are available in black and white finish.

Ka M es una lámpara de pie, que emite luz directa. Sus líneas sencillas y elegantes dibujan una estilizada estructura de listones de madera de haya, con forma de trípode y unidos mediante cordón de cuero. En la parte superior destaca una pequeña tulipa de metal que penetra en el mástil y emite una luz ideal para la lectura.

Ka M cuenta con dos versiones:

Essential y Functional.

Essential tiene un carácter minimal y Functional un carácter más práctico y singular, ya que incluye una bandeja de piel natural y un toque de color en sus patas. Disponible en acabado blanco y negro para ambas versiones.





LIVE DESIGN





COLLECTION

KA LAMP XL

Ka XL is a standard lamp, which radiates ambient light. Its simple and elegant lines are drawn from a stylish structure of beech wood slats, a tripod shape and joined together by a leather thread. At the top of the pole is a large metal lampshade which filters the light through a natural cotton diffuser.

Ka XL is available in two versions:

Essential y Functional.

Essential has a minimal character and Functional has a more practical and unique character, as it includes a natural leather tray and a splash of colour in its legs. Both variations are available in black and white finish.

Ka XL es una lámpara de pie, que emite luz ambiental. Sus líneas sencillas y elegantes dibujan una estilizada estructura de listones de madera de haya, con forma de trípode y unidos mediante cordón de cuero. En la parte superior destaca una gran tulipa de metal que penetra en el mástil y tamiza la luz mediante un difusor natural de algodón.

Ka XL cuenta con dos versiones:

Essential y Functional.

Essential tiene un carácter minimal y Functional un carácter más práctico y singular, ya que incluye una bandeja de piel natural y un toque de color en sus patas. Disponible en acabado blanco y negro para ambas versiones.





LIVE DESIGN





LIVE DESIGN

COLLECTION

BATEA



BATEA S

The smallest member of the Batea family, inspired by traditional serving trays, provides extra functionality with its solid wooden tray, easy to remove and use. A side tray table that combines tradition and modernity, adapting to the dynamics of each space.

With clean, rounded lines, this piece comprises a tray and three legs made of solid wood that can be easily attached to a lacquered metal structure.

Available in seven different finishes, two natural finishes made of oak wood and five in colour made of ash.

La pequeña de la familia Batea, inspirada en las tradicionales bandejas para servir, aporta funcionalidad extra con su bandeja de madera maciza, fácil de extraer y de utilizar. Una mesa que fusiona tradición y modernidad, adaptándose al dinamismo de cada espacio.

De líneas limpias y redondeadas, se compone de una bandeja y tres patas de madera maciza, que se montan fácilmente sobre una estructura de metal lacado.

Disponible en siete acabados diferentes, dos acabados naturales elaborados con madera de roble y cinco en color elaborados con madera de fresno.





LIVE DESIGN





LIVE DESIGN

COLLECTION

BATEA M

The medium size member of the Batea family has an extra functionality, a small storage space under its table top where you can keep those small everyday objects out of sight. A coffee table that combines tradition and modernity, adapting to the dynamics of each space.

With clean, rounded lines, this piece comprises a tray and three legs made of solid wood that can be easily attached to a lacquered metal structure.

Available in seven different finishes, two natural finishes made of oak wood and five in colour made of ash.

La mediana de la familia Batea, cuenta con una funcionalidad extra, un pequeño espacio de almacenaje bajo su base que permite recoger esos pequeños objetos cotidianos. Una mesa que fusiona tradición y modernidad, adaptándose al dinamismo de cada espacio.

De líneas limpias y redondeadas, se compone de una bandeja y tres patas de madera maciza, que se montan fácilmente sobre una estructura de metal lacado.

Disponible en siete acabados diferentes, dos acabados naturales elaborados con madera de roble y cinco en color elaborados con madera de fresno.



LIVE DESIGN







COLLECTION

BATEA L



The largest member of the Batea family has a large storage space that opens up when you slide back the table top. A coffee table that combines tradition and modernity, adapting to the dynamics of each space, keeping everything in order.

With clean, rounded lines, this piece comprises a table top and four legs made of solid wood that can be easily attached to a lacquered metal structure.

Available in oak and black and white lacquered metal finishes.

La mayor de la familia Batea, cuenta con un gran espacio de almacenaje que se descubre al deslizar su base. Una mesa que fusiona tradición y modernidad, adaptándose al dinamismo de cada espacio, facilitando su orden.

De líneas limpias y redondeadas, se compone de base y cuatro patas de madera maciza, que se montan fácilmente sobre una estructura de metal lacado y madera.

Disponible en madera de roble y acabados metal lacado negro y blanco.





LIVE DESIGN



LIVE DESIGN

COLLECTION

ACCESSORIES



COLLECTION

PELICAN



Close your eyes and imagine a flock of pelicans in flight over the ocean, capable of fishing with their big bag who have on the bottom of its long beak. Inspired by this bird we present Pelican.

Pelican, handmade versatile wall organizer that adapts to every environment and allows us to store or hang our everyday objects.

Wood structure acts as a container and metal sheet acts as a wall hanger, with two/ three hidden hooks (depend on the size). Available in 3 sizes and 5 different finishes.

Cierra los ojos e imagina una bandada de pelicanos sobre volando el océano, capaces de pescar con su gran bolsa que tienen debajo de su largo pico. Inspirados en este ave presentamos Pelican.

Pelican, son unas estanterías de pared que nos ayudan a mantener organizado nuestros objetos cotidianos.

Están compuestas por un contenedor elaborado en madera de contrachapado y por una estructura de metal que actúa a su vez de perchero, con dos o tres (dependiendo del tamaño) ganchos ocultos. Disponible en 3 tamaños y 5 acabados diferentes.







COLLECTION

KESITO

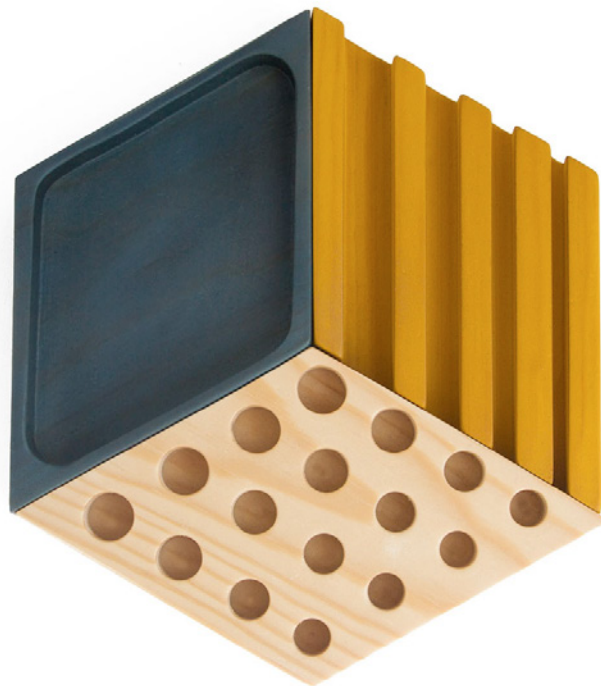

Kesito is a desk organizer that helps us to order those little objects that we always have on hand; pencils, paper clips, business cards and of course, we can use it as a vertical holder for our Smartphone. It is composed of three diamond-shaped pieces, with which we can play and form a hexagon. It is made in solid pine, two of the three pieces have a touch of color.

Kesito es un organizador de escritorio que nos ayuda a mantener en orden todos esos pequeños objetos que siempre tenemos a mano; lapiceros, clips, tarjetas de visita y por su puerto, podemos usarlo como soporte vertical de nuestro Smartphone. Compuesto por tres rombos, podemos jugar a formar diferentes figuras. Elaborado en pino, dos de sus tres piezas tienen un toque de color.



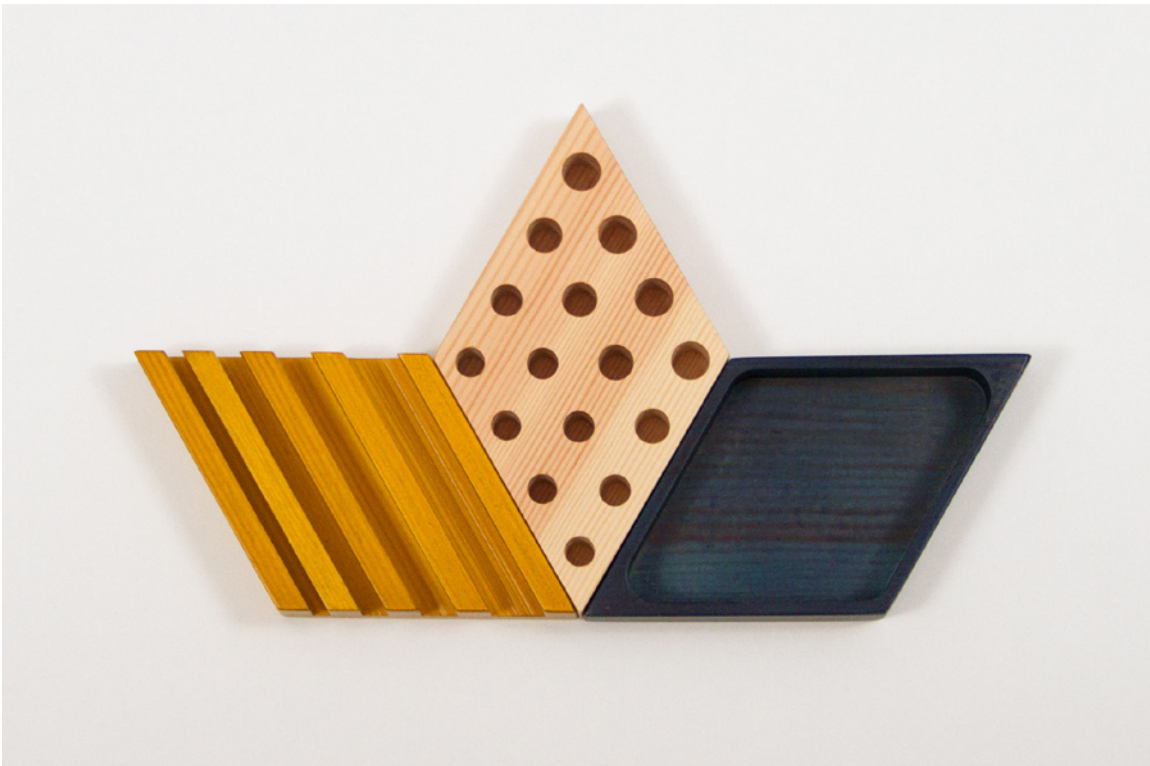
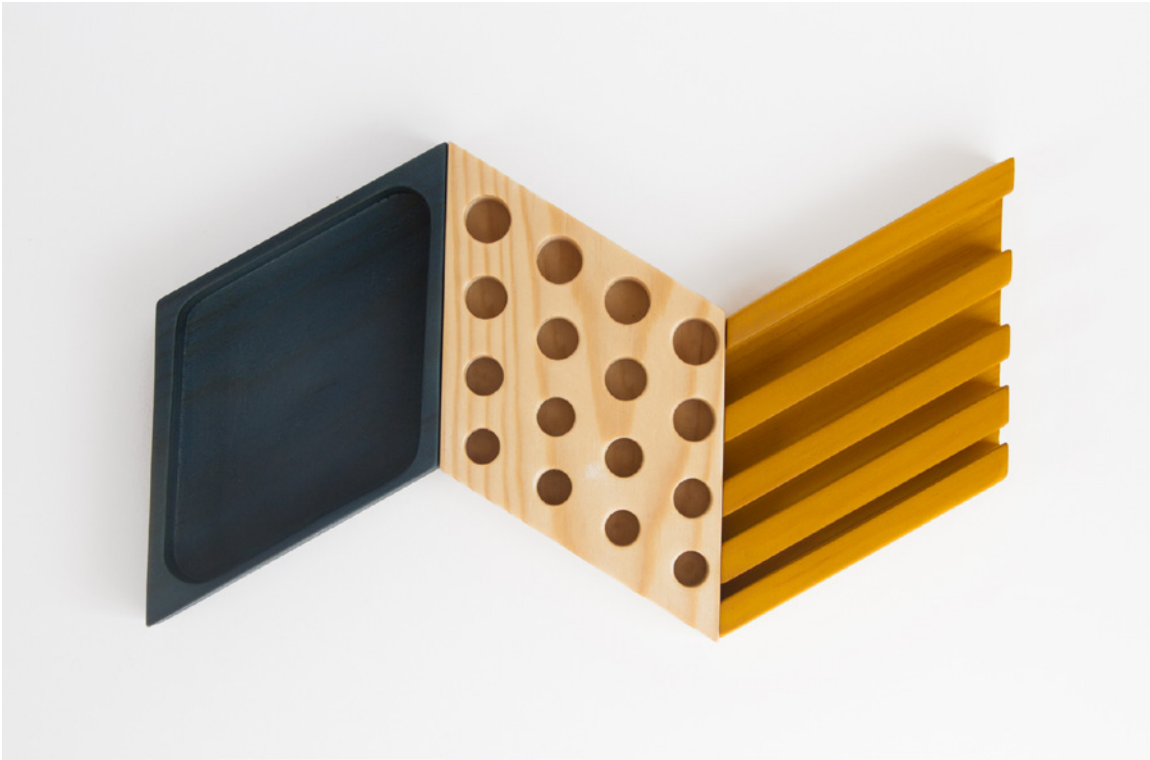



COLLECTION

ETNA



Etna is a collection of large candle holders, ideal to give any environment a splash of light and colour. Its simple and clean lines come from a conical shape made of solid pine wood. At the top are curves which evoke lava flows gliding down the slope of a volcano. This colour highlights the natural shades in the wood thanks to its translucency.

This collection allows for the creation a great variety of arrangements, as it is available in three different sizes and in a six colour palette.

Etna es una colección de candelabros gigantes, ideales para dar un toque de luz y color a cualquier ambiente. Sus líneas sencillas y limpias crean una pieza tronco cónica elaborada de madera maciza de pino; en su parte superior se dibujan unas curvas que evocan lenguas de lava deslizándose por la ladera de un volcán, esta zona de color permite distinguir las betas de la madera gracias a su translucidez.

La colección ofrece la posibilidad de crear una gran variedad de composiciones, ya que dispone de tres tamaños diferentes y una paleta de seis colores.



LIVE DESIGN





LIVE DESIGN

COLLECTION

ETNA MINI

Etna Mini is a collection of candle holders, ideal to give any environment a splash of light and colour. Its simple and clean lines come from a conical shape made of solid pine wood. At the top are curves which evoke lava flows gliding down the slope of a volcano. This colour highlights the natural shades in the wood thanks to its translucency.

This collection is available in three-piece packs and in a six colour palette.

Etna Mini es una colección de candelabros, ideal para dar un toque de luz y color a cualquier ambiente. Sus líneas sencillas y limpias crean una pieza tronco cónica elaborada de madera maciza de pino; en su parte superior se dibujan unas curvas que evocan lenguas de lava deslizándose por la ladera de un volcán, esta zona de color permite distinguir las betas de la madera gracias a su translucidez.

La colección esta disponible en packs de tres piezas y en una paleta de seis colores.





LIVE DESIGN





TECHNICAL SPECIFICATIONS

.

TECHNICAL SPECIFICATIONS

KA LAMP S

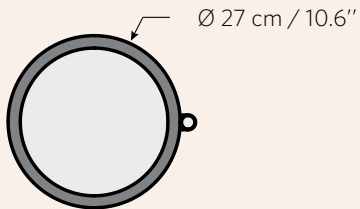
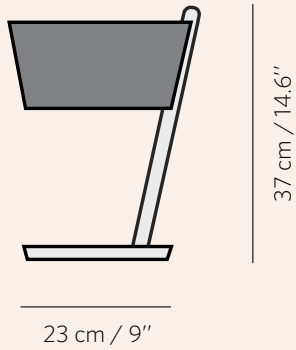

- KA-S-W White Ka Lamp
- KA-S-B Black Ka Lamp



- Solid beech wood and natural leather
- Lacquered metal lampshade
- 100% cotton diffuser
- 2m cloth covered wire
- Included Energy saving bulb
- Handswitch
- Matte finish
- Clean with damp cloth
- Easily assembled
- Delivered in a flat package

- Max.1x15w, E-14, 230V, 50Hz
- CE AU-NZ UK-Ireland

- Max.1x15w, E-12, 120V, 60Hz
- USA

1 Kg / 2.2 lbs

1.6 Kg / 3.5 lbs
910 x 28 x 5H cm / 35.8" x 11" x 2"H



TECHNICAL SPECIFICATIONS

KA LAMP M

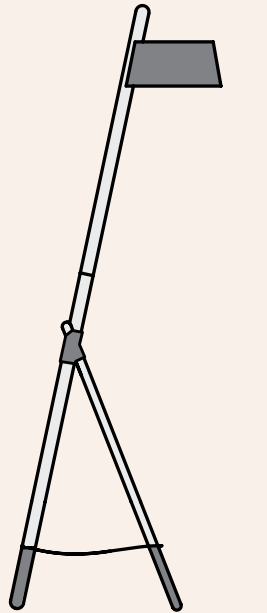

150 cm / 59"

45 cm / 17.7"

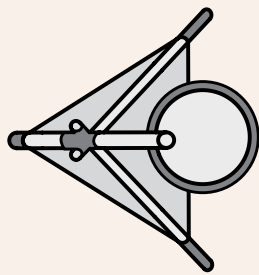

60 cm / 23.6"

- KA-M-EW Medium White Ka Lamp
- KA-M-FW Medium White Ka Lamp with tray
- KA-M-EB Medium Black Ka Lamp
- KA-M-FB Medium Black Ka Lamp with tray



- Solid beech wood and natural leather
- Lacquered metal lampshade
- 2,5m cloth covered wire
- Included Energy saving bulb
- Handswitch
- Matte finish
- Clean with damp cloth
- Easily assembled
- Delivered in a flat package



Max.1x15w. E-14. 230V. 50Hz



Max.1x15w. E-12. 120V. 60Hz



 1.8 Kg / 4 lbs

 2.5 Kg / 5.5 lbs
910 x 28 x 5H cm / 35.8" x 11" x 2"H



TECHNICAL SPECIFICATIONS

KA LAMP XL

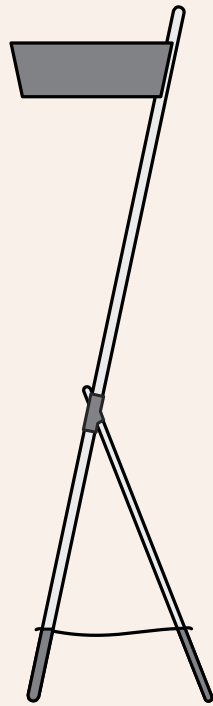

195 cm / 77"

50 cm / 19.7"

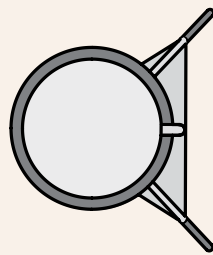

65 cm / 25.6"

- KA-XL-EW Extra Large White Ka Lamp
- KA-XL-FW Extra Large White Ka Lamp with tray
- KA-XL-EB Extra Large Black Ka Lamp
- KA-XL-FB Extra Large Black Ka Lamp with tray



Solid beech wood and natural leather
Lacquered metal lampshade
100% cotton diffuser
3,5m cloth covered wire
Included Energy saving bulb
Footswitch
Matte finish
Clean with damp cloth
Easily assembled
Delivered in a flat package



Max.1x15w. E-14. 230V. 50Hz



CE AU-NZ UK-Ireland

Max.1x15w. E-12. 120V. 60Hz



USA



2.8 Kg / 6.2 lbs



4 Kg / 8.9 lbs

137 x 39 x 5H cm / 54" x 15.5" x 2"H



BATEA S

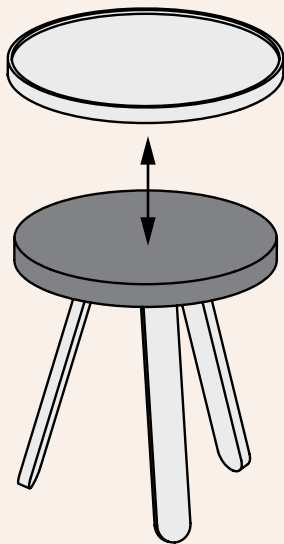
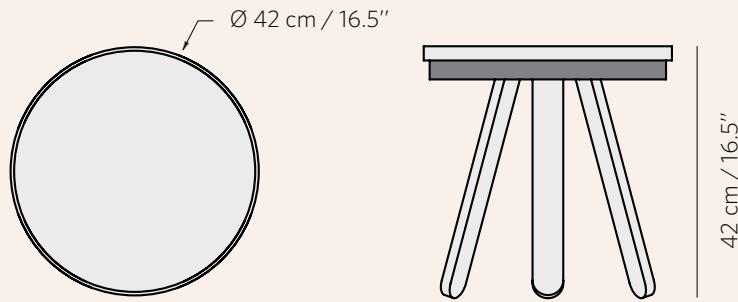

- BA-S-WB Small Walnut-Black Batea tray table
- BA-S-OW Small Oak-White Batea tray table
- BA-S-OB Small Oak-Black Batea tray table
- BA-S-WHT Small White Batea tray table
- BA-S-BLK Small Black Batea tray table
- BA-S-GRY Small Grey Batea tray table - RAL 7040
- BA-S-BLU Small Blue Batea tray table - RAL 5011
- BA-S-GRN Small Green Batea tray table - RAL 6033



- Table lid and legs made of solid ash/ oak/ walnut
- Structure in lacquered steel
- Matte finish
- Clean with damp cloth
- Easily assembled
- Delivered in a flat package

●
⚠ 4 Kg / 8.8 lbs

📦 4.5 Kg / 10 lbs
445 x 45 x 12H cm / 18" x 18" x 5"H

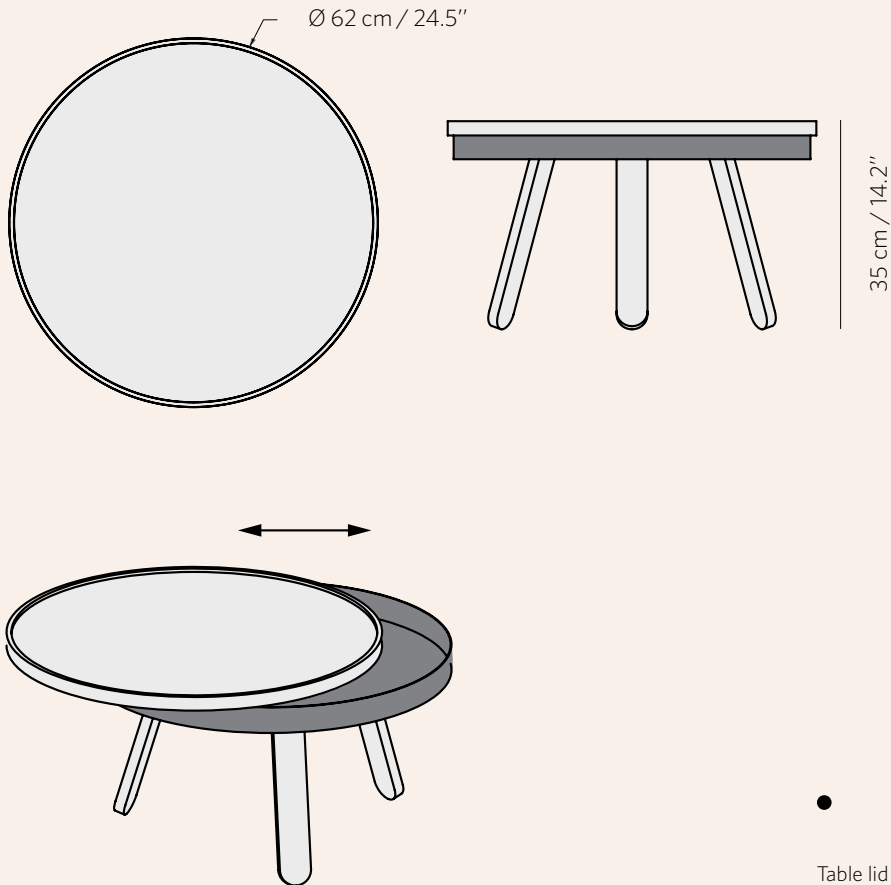

BATEA M



- BA-M-WB Medium Walnut-Black Batea coffee table
- BA-M-OW Medium Oak-White Batea coffee table
- BA-M-OB Medium Oak-Black Batea coffee table
- BA-M-WHT Medium White Batea coffee table
- BA-M-BLK Medium Black Batea coffee table
- BA-M-GRY Medium Grey Batea coffee table - RAL 7040
- BA-M-BLU Medium Blue Batea coffee table - RAL 5011
- BA-M-GRN Medium Green Batea coffee table - RAL 6033



- Table lid fully removable
Storage depth of 4,5 cm
Table lid and legs made of solid ash/ oak/ walnut
Structure in lacquered steel
Matte finish
Clean with damp cloth
Easily assembled
Delivered in a flat package

-  8 Kg / 17.6 lbs
-  9 Kg / 19.8 lbs
65 x 65 x 14H cm / 25.6" x 25.6" x 5.5"H

TECHNICAL SPECIFICATIONS

BATEA L

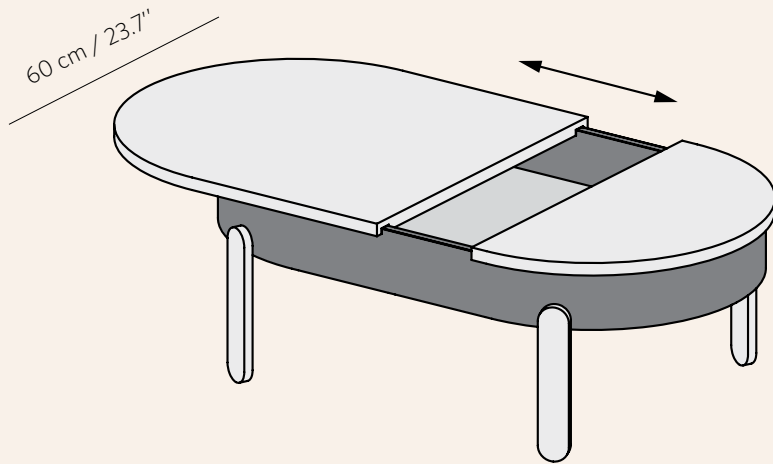
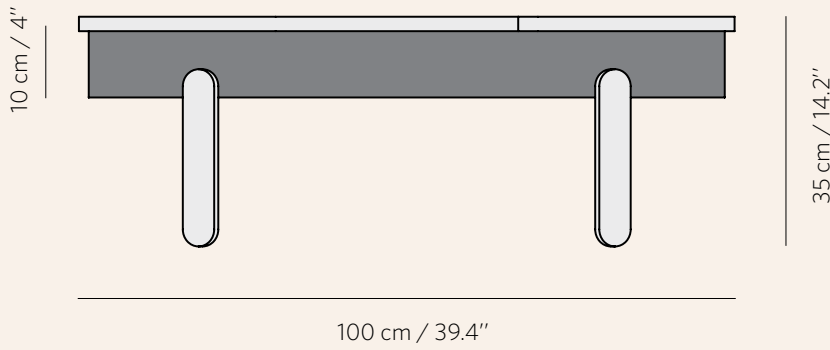

- BA-L-WB Large Walnut-Black Batea coffee table
- BA-L-OW Large Oak-White Batea coffee table
- BA-L-OB Large Oak-Black Batea coffee table



- Sliding lid and legs made of solid oak/ walnut
- Structure in lacquered steel
- Matte finish
- Clean with damp cloth
- Easily assembled
- Delivered in a flat package

-  14 Kg / 30.8 lbs

-  15 Kg / 33 lbs
- 105 x 65 x 15H cm / 41.3" x 25.6" x 6"H

PELICAN

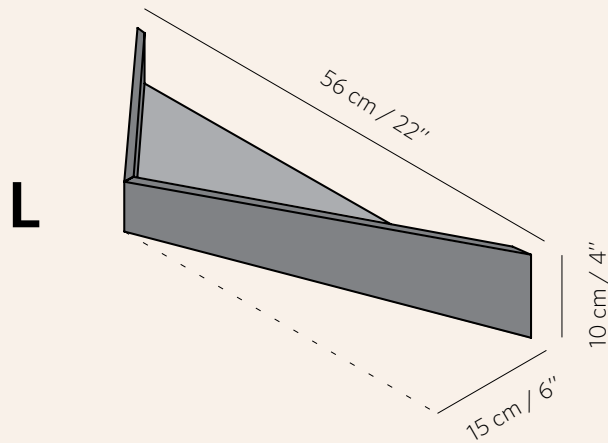
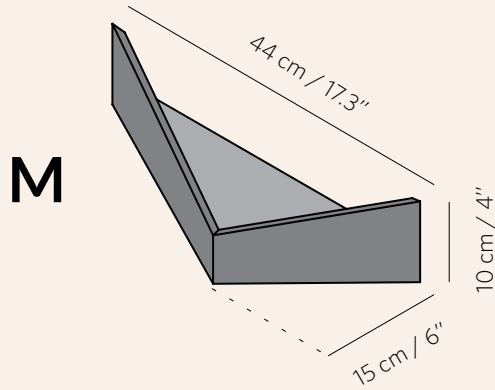
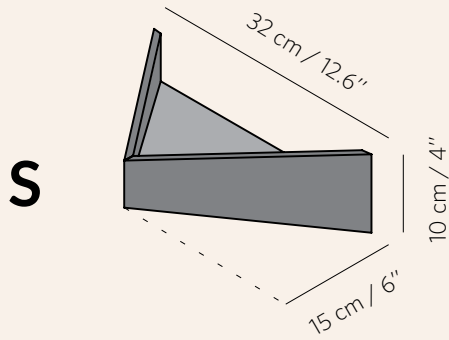

PE- S / M / L -

- WLN Walnut Pelican shelf
- OAK Oak Pelican shelf
- WHT White Pelican shelf
- BLK Black Pelican shelf
- GRY Grey Pelican shelf - RAL 7040



- Plywood and lacquered steel
- Hidden hooks PE-S/M (x2)
- Hidden hooks PE-L (x3)
- Matte finish
- Clean with damp cloth
- Easily assembled
- Load capacity: 30kg pr. shelf

UU PE-S/M (x2) - L (x3)

- △ PE-S 0.70 Kg / 1.5 lbs
- PE-M 0.80 Kg / 1.9 lbs
- PE-L 1.1 Kg / 2.5 lbs

- ☰ PE-S 1.2 Kg / 2.7 lbs
31 x 23 x 13H cm / 12.2" x 9" x 5"H
- PE-M 1.4 Kg / 3 lbs
44 x 24 x 13H cm / 17.3" x 9.4" x 5"H
- PE-L 1.6 Kg / 3.5 lbs
57 x 25 x 13H cm / 22.5" x 9.8" x 5"H

KESITO

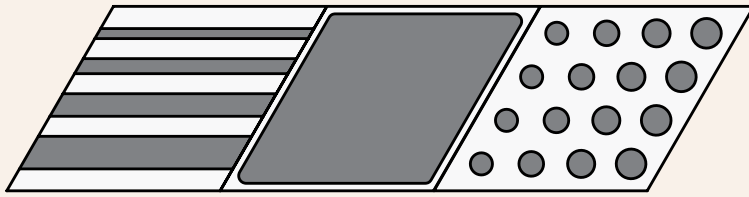

7.5 cm / 3"

8.5 cm / 3.4"

30 cm / 11.8"

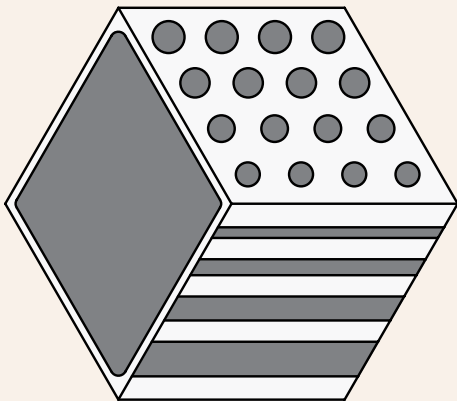

15 cm / 5.9"

17 cm / 6.7"

- Three diamond-shaped pieces
Made of solid pine with a touch of color
Matte finish
Clean with damp cloth

-  0.2 Kg / 0.45 lbs

-  0.3 Kg / 0.7 lbs
23 x 15 x 3H cm / 9" x 6" x 1.2"H

K-B Kesito desk organizer



ETNA

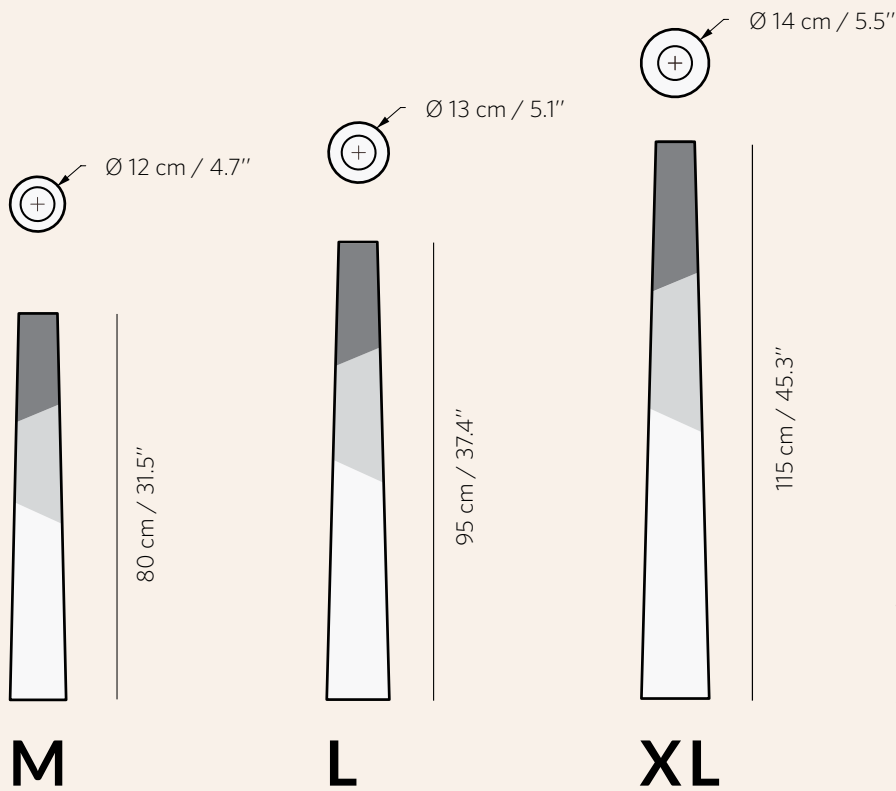

M

L

XL

ET- M / L / XL -

- WHT White Etna candle holder
- BLK Black Etna candle holder
- BLU Blue Etna candle holder
- YEL Yellow Etna candle holder
- RED Red Etna candle holder
- GRN Green Etna candle holder



Made of solid pine with a touch of color
Tealights or candles up to Ø 60mm / 2.3"
Glass cup protector between candle and wood
Matte finish
Clean with damp cloth



- ET-M 3.3 Kg / 7.3 lbs
- ET-L 4.2 Kg / 9.3 lbs
- ET-XL 5.7 Kg / 12.6 lbs



- ET-M 3.5 Kg / 7.5 lbs
Ø 12 x 82H cm / Ø 4.7" x 32"H
- ET-L 4.5 Kg / 10 lbs
Ø 15 x 97H cm / Ø 6" x 38.2"H
- ET-XL 6 Kg / 13.3 lbs
Ø 15 x 120H cm / Ø 6" x 47"H

ETNA MINI

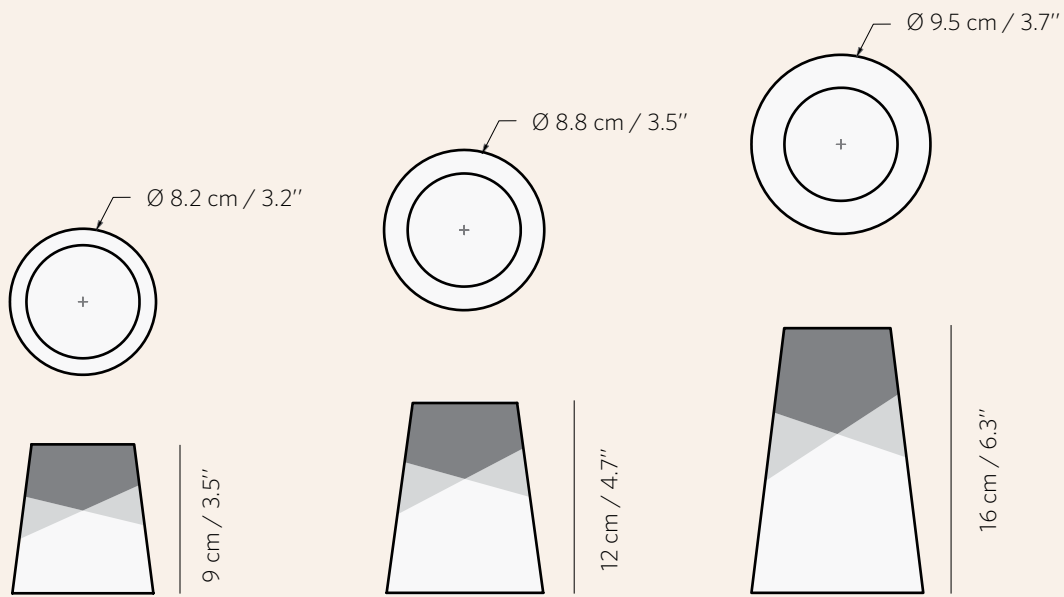



- ETM-WHT White Etna Mini
- ETM-BLK Black Etna Mini
- ETM-BLU Blue Etna Mini
- ETM-YEL Yellow Etna Mini
- ETM-RED Red Etna Mini
- ETM-GRN Green Etna Mini



- Set of three
- Made of solid pine with a touch of color
- Tealights or candles up to \varnothing 40mm / 2,3"
- Glass cup protector between candle and wood
- Matte finish
- Clean with damp cloth



 1 Kg / 2.2 lbs

 1.2 Kg / 2.6 lbs
 \varnothing 10 x 42H cm / \varnothing 4" x 16.5"H



WOODENDOT

HEAD OFFICE

Calle Bravo Murillo 183, 6º.
28020 MADRID - SPAIN

PRODUCTION

Calle Carracuellar s/n.
47420 ÍSCAR, VALLADOLID - SPAIN

CONTACT

info@woodendot.com
www.woodendot.com
+34 686 768 483

PHOTOGRAPHY

CARMELA.WORK / WOODENDOT ARCHIVE

CATALOG DESIGN

CARMELA.WORK
www.carmela.work

WOODENDOT